

SS341

Generator Automatic Voltage Regulator Operation Manual



Self Excited Automatic Voltage Regulator
Compatible with Newage MX341*

* Use for reference purpose only and not a genuine Newage product.

1. INTRODUCTION

| | | | |
|---|---|------------------------------------|--------------------------------|
| Sensing Input | | Analogue Input | |
| Voltage | 190 ~ 264 VAC Max, 1 phase, 2 wire | Max. Input | ± 5 VDC |
| Frequency | 50 / 60 Hz, nominal | Sensitivity | 1V for 5% generator volts |
| | | Input Resistance | 1K ohm |
| Power Input (PMG) | | Droop Input | |
| Voltage | 140 ~ 220 VAC Max, 3 phase 3 wire | Burden | 10 ohm |
| Current | 3A phase | Max. sensitivity | 0.07 A for 5% droop (PF=0) |
| Frequency | 100 ~ 120 Hz, nominal | Max. input | 0.33 A |
| Output | | Over Voltage Detector Input | |
| Voltage | Max. 120 VDC | Set point | 300V. Time delay 1 Sec (fixed) |
| Current | Continuous 2.7A Intermittent 6A for 10 sec | CB trip coil volts | 10 ~ 30 VDC |
| Resistance | Min. 15 ohm | CB trip coil resistance | 20 ~ 60 ohms |
| Voltage Regulation | | Over Excitation Protection | |
| < ± 1% (with 4% engine governing) | | Set point | 75 VDC |
| | | Time delay | 10 sec (fixed) |
| Voltage Build-up | | Typical System Response | |
| Residual voltage at AVR terminal > 5 VAC | | AVR response | 10 ms |
| | | Filed current to 90% | 80 ms |
| | | Machine Volts to 97% | 300 ms |
| Thermal Drift | | Environmental | |
| 0.03% per °C change in AVR ambient | | 100Hz ~ 2kHz | 3.3g |
| External Volts Adjustment | | Relative Humidity | |
| ± 10% with 1K ohm 1 watt trimmer | | 0~70 °C | 95% (see note 6) |
| Unit Power Dissipation | | Operating temperature | |
| Max. 12 watt | | -40 to +70 °C | |
| Under Frequency Protection (Factory Setting) | | Storage temperature | |
| Set point 95% Hz | | -55 to +80 °C | |
| Slope 170% down to 30 Hz | | Dimensions | |
| | | 150mm L * 135mm W * 40mm H | |
| Current Limit Input | | Weight | |
| 10 ohms burden | | 394g ± 2% | |
| Sensitivity range | 0.5 ~ 1A | | |
| Soft Start Ramp Time | | | |
| 3 sec. | | | |

2. GENERAL DESCRIPTION

SS341 is a two phase sensed Automatic Voltage Regulator and forms part of the excitation system for a brush-less generator. Excitation power is derived from a three-phase permanent magnet generator (PMG), to isolate the AVR control circuits

from the effects of nonlinear loads and to reduce radio frequency interference on the generator terminals. Sustained generator short circuit current is another feature of the PMG system.

- fi The AVR senses the voltage in the main generator winding and controls the power fed to the exciter stator and hence the main rotor to maintain the generator output voltage within the specified limits, compensating for load, speed, temperature and power factor of the generator.
- fi Soft start circuitry is included to provide a smooth controlled build up of generator output voltage.
- fi A frequency measuring circuit continually monitors the shaft speed of the generator and provides under-speed protection of the excitation system by reducing the generator output voltage proportionally with speed below a pre-settable threshold. A further enhancement of this feature is an adjustable volts per Hertz slope to improve engine recovery time on turbo charged engines. Soft start circuitry is included to provide a smooth controlled build up of generator output voltage.
- fi Uncontrolled excitation is limited to a safe period by internal shutdown of the AVR output device. This condition remains latched until the generator has stopped.
- fi Provision is made for the connection of a remote voltage trimmer, allowing the user fine control of the generator's output.

- fi An analogue input is provided allowing connection to a controller or other external devices with compatible output.
- fi The AVR has the facility for droop CT connection, to allow parallel running with other similarly equipped generators.

NOTE :

1. Derate linearly from 3.7A at 50 °C to 2.7A at 70 °C.
2. The stated voltage regulation may not be maintained in the presence of certain transmitted radio signals. Any change in regulation will fall within the limits in Criteria B of S.EN.61000-6-2 : 2001.
3. After 10 minutes.
4. Applies to Mod status E onwards. Generator de-rate may apply. Check with factory. Factory set, semi-sealed, jumper selectable.
5. Any device connected to the analogue input must be fully looting (galvanically isolated from ground), with an insulation strength of 500Vac.
6. Non condensing.

3. SUMMARY OF AVR CONTROLS

| CONTROL | FUNCTION | DIRECTION |
|-----------|--|---|
| VOLTS | To adjust generator output voltage | Clockwise increases output voltage |
| STABILITY | To prevent voltage hunting | Clockwise increase the damping effect |
| UFRO | To set the UFRO knee point | Clockwise reduces the knee point frequency |
| DROOP | To set the generator droop to 5% at 0pf | Clockwise increases the droop |
| TRIM | To optimize analogue input sensitivity | Clockwise increases the gain or sensitivity |
| EXC | To set the over excitation cut off level | Clockwise increase the cut off level |
| DIP | To set the frequency related voltage dip | Clockwise increases the voltage dip |

4. ADJUSTMENT OF AVR CONTROLS

4.1 Voltage Adjustment

The generator output voltage is set at the factory, but can be altered by careful adjustment of the VOLTS control on the AVR board, or by the external hand trimmer if fitted.

Terminals 1 and 2 on the AVR will be fitted with a shorting link if no hand trimmer is required.

WARNING

Do not increase the voltage above the rated generator voltage. If in doubt, refer to the rating plate mounted on the generator case.

Do not ground any of the hand trimmer terminals, as these could be above earth potential. Failure to observe this could cause equipment damage.

If a replacement AVR has been fitted or re-setting of the VOLTS adjustment is required, proceed as follows :

1. Before running generator, turn the VOLTS control fully anti-clockwise.
2. Turn remote volts trimmer (if fitted) to midway position.
3. Turn STABILITY control to midway position.
4. Connect a suitable voltmeter (0~300V ac) across line to neutral of the generator.
5. Start generator set, and run on no load at nominal frequency e.g. 50~53Hz or 60~63Hz.
6. If the red Light Emitting Diode (LED) is illuminated, refer to the Under Frequency Roll Off (UFRO) adjustment.
7. Carefully turn VOLTS control clockwise until rated voltage is reached.
8. If instability is present at rated voltage, refer to stability adjustment, then re-adjust voltage if necessary.
9. Voltage adjustment is now completed.

4.2 Stability Adjustment

- fi The AVR includes stability or damping circuit to provide good steady state and transient performance of the generator.
- fi A jumper link selector is provided to optimize the response of the stability circuit to various size generators.
- fi The link should be positioned as shown in the diagram according to the kW rating of the generator. The correct setting of the Stability adjustment can be found by running the generator at no load and slowly turning the stability control anti-clockwise until the generator voltage starts to become unstable. The optimum or critically damped position is slightly clockwise from this point (i.e. where the machine volts are stable but close to the unstable region).

4.3 Under Frequency Roll Off (UFRO) Adjustment

The AVR incorporates an under-speed protection circuit which gives a volts/Hz characteristic when the generator speed falls below a presentable threshold known as the "knee" point. The red Light Emitting Diode (LED) gives indication that the UFRO circuit is operating.

The UFRO adjustment is preset and sealed and only requires the selection of 50 or 60Hz and 4 pole or 6 pole, using the jumper link as shown in the diagram. For optimum setting, the LED should illuminate as the frequency falls just below nominal, i.e. 47Hz on a 50Hz system or 57Hz on a 60Hz system.

4.4 DROOP Adjustment

Generators intended for parallel operation are fitted with a quadrature droop C.T. which provides a power factor dependent signal for the AVR. The C.T. is connected to S1, S2 on the AVR, (see generator wiring diagram for details). The DROOP adjustment is normally preset in the works to give 5% voltage droop at full load zero power factors. Clockwise increases the amount of C.T. signal injected into the AVR and increases the droop with lagging power factor ($\cos \emptyset$). With the control fully anti-clockwise there is no droop.

4.5 Trim Adjustment

- fi An analogue input (A1 A2) is provided to connect to the controller or other devices. It is designed to accept dc signals up to ± 5 volts.
- fi The dc signal applied to this input adds to the AVR sensing circuit. A1 is connected to the AVR 0 volts. Positive on A2 increases excitation. Negative on A2 decreases excitation.
- fi The TRIM control allows the user to adjust the sensitivity of the input. With TRIM fully anti-clockwise the externally applied signal has no effect. Clockwise it has maximum effect.
- fi Normal setting is fully clockwise when used with a controller.

WARNING

Any devices connected to this input must be fully floating and galvanically isolated from ground, with an insulation capability of 500V ac. Failure to observe this could result in equipment damage.

4.6 Er Excitation (EXC) Adjustment

This adjustment is set and sealed in the works and should not be tampered with. An over excitation condition is indicated by the illumination of the red LED which also indicates under-speed running and over-volts.

The generator must be stopped to reset an over-excitation trip.

4.7 DIP Adjustment

This feature is mostly used when the generator is coupled to turbo charged engines with limited block load acceptance. The feature works by increasing the V/Hz slope to give greater voltage roll off in proportion to speed.

With the DIP control fully anti-clockwise, the generator voltage will follow the normal V/Hz line as the speed falls below nominal. Turning the DIP control clockwise provides greater voltage roll off aiding engine recovery.

5. FITTING AND OPERATING (Refer to generator wiring diagram for connection details)

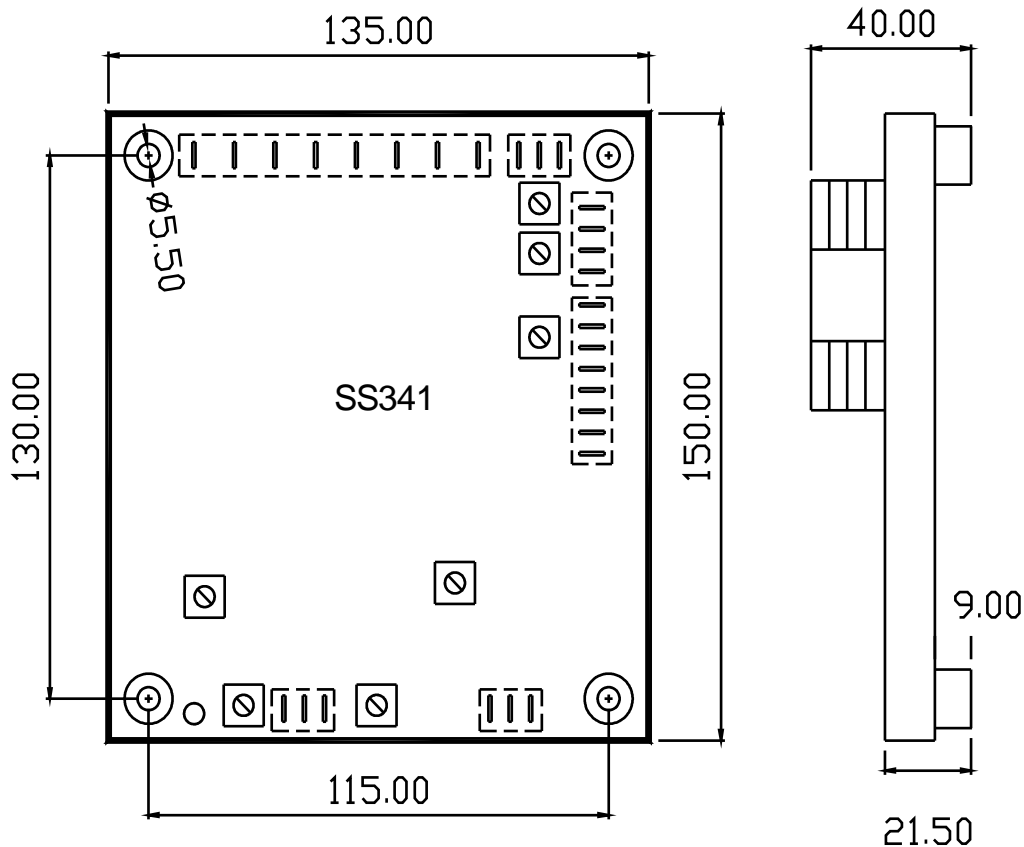

Outline Drawing
Figure 1

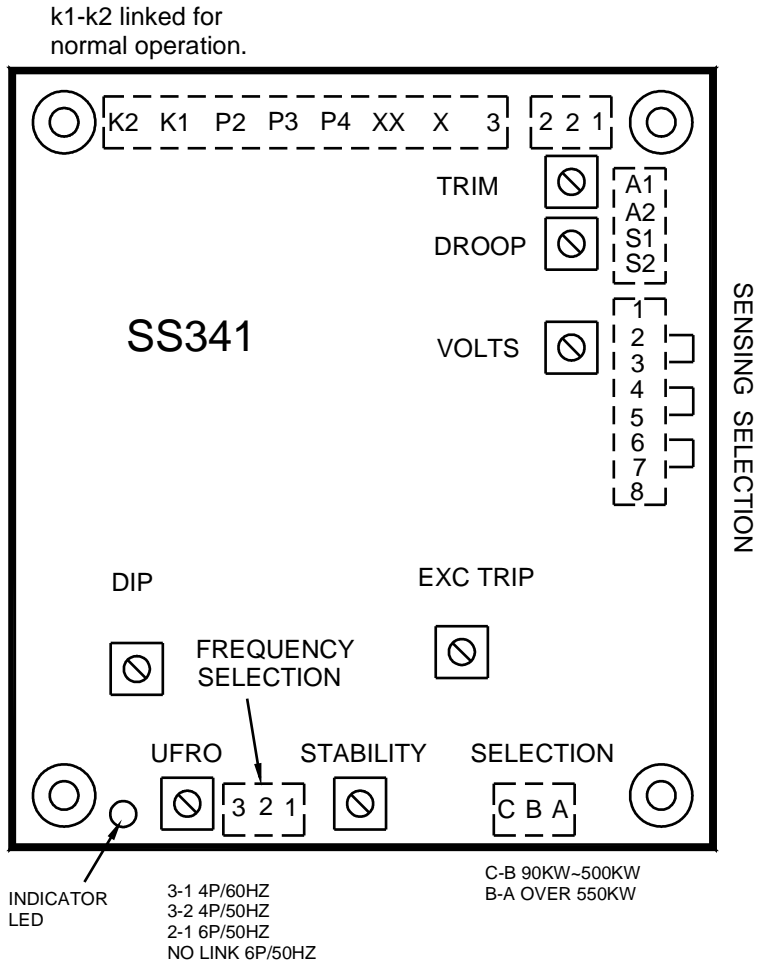

Figure 2 Jisposition Drawing

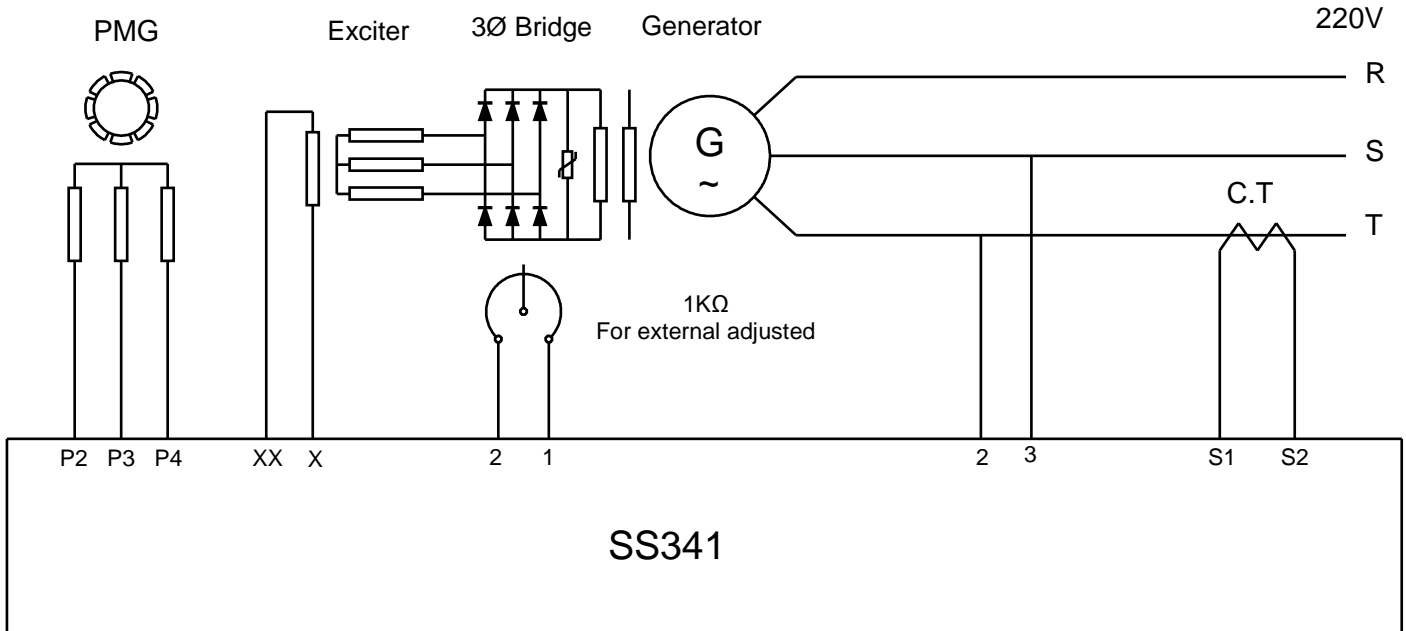

Figure 3 Wiring Drawing

Note : When the system voltage over 220VAC, a transformer is necessary at sensing input terminal