

Universal

SS-053

Generator Automatic Voltage Regulator Operation Manual

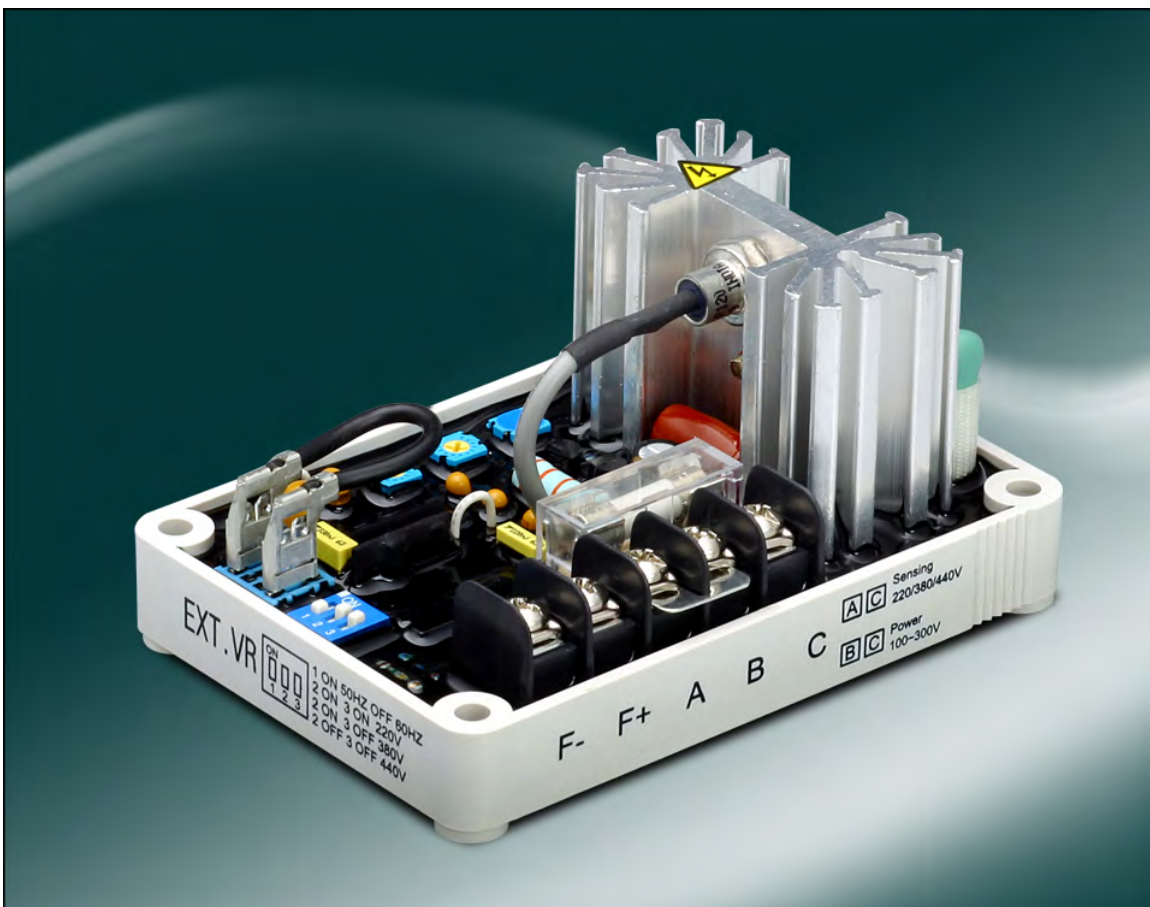

Self Excited Automatic Voltage Regulator
5 Amp AVR For General Generators

1. INTRODUCTION

Sensing hput

Voltage 220 / 380 /440 VAC, 1 phase2 wire
DIP switch selectable
Frequency 50 /60 Hz, DIP switch selectable

Power hput

Voltage 100 ~ 300 VAC, 1 phase 2 wire
or internal Auxiliary Winding

Output

Voltage Max. 63 VDC @ 220 VAC input
Max. 90 VDC @ 240 VAC input
Current Continuous 5A
Intermittent 7A for 10 sec
Resistance Min. 15 ohm Max. 100 ohm

Voltage Regulation

< ± 0.5% (with 4% engine governing)

Voltage Build-up

Residual voltage at AVR terminal > 5 VAC

Thermal Drift

0.03% per °C change in AVR ambient

External Volts Adjustment

7% with 1K ohm 1 watt timmer

EMI Suppression

Internal electromagnetic interference filtering

Unit Power Dssipation

Max. 8 watt

Under Frequency Protection (Factory Setting)

60 Hz system presets knee point at 55 Hz
50 Hz system presets knee point at 45 Hz

Soft Start Ramp Time

3 sec.

Dimensions

101mm L * 69mm W * 47.5mm H

Weight

183g ± 2%

2. WIRING

In a standard AVR, when the generator has an unbalanced load, the NEUTRAL conducts the current from this unbalance load, and the voltage from the N to the 3 phases constantly changes the sensing reference input voltage to the AVR making it hard to have a constant output voltage on the generator.

This model AVR corrects this problem by sensing directly from the output of the generator being it 220, 380, or 490 volts.

1. When the rated phase voltage of the generator is 220VAC, the input terminals B, C and sensing terminals A, C are the same (as in figure 3 factory setting). or connect independent. (as show as figure 2).
2. But when the voltage of the generator is 380V, 480V, the power input terminals B, Cand sensing terminals A, C are connected separately (as show in Figure 4 or figure 5). Power inputs B and C must never go over 300 VAC.

3. F+, F- terminals connect to the generator field. (J and K)

4.- For use with independet power winding see Fig 10

EXT.VR is rated at (1K Ohm 1W) Keep terminals shorted when the external pot is not used.

P.S. : A, B, C, F+, F- usage AWG 16 1.25 mm² wire gauge are 85°C above 600V.

The EXT.VR connection wires must be insulated.

3. ADJUSTMENTS

Set voltage setting for 220V / 380V / 440V and frequency setting for 50/60HZ is show in figure7. double check the voltage/frequency setting before start the generator.

CAUTION :

THE GENERATOR OR AVR MAY BE DAMAGED IF THE VOLTAGE / FREQUENCY SELECTOR SETTING IS SET WRONG.

UFRO DIP:

Close - refer to solid curve in Figure 8.

Open - refer to dotted curve in Figure 8.

build-up voltage for the regulator. If reversing the field wires does not induce build-up, and the residual voltage is less than then 5 Vac, stop the engine and proceed with the next steps

- 1 Before starting the generator, set the voltage and stability, adjustment full CCW and with the engine runs, set the voltage adjustment CW to the voltage required. (If you are using an external remote pot, set this pot to its center position before adjusting the pot on the AVR)

1. With the engine at rest and the regulator's field wires disconnected, apply the DC voltage from a 12 volt battery to the fields with the Positive to F+ and Negative to F-, using a current-limiting resistor from 3 to 5 ohms 20 watt. (The set battery is OK.)

2. Adjust the "STAB" move CW slowly until the voltage becomes unstable and then back it up. When under-adjusted, the AVR reaction time is slow. By using an old-fashioned needle voltmeter, adjusting the "stability" is easier when you are looking for a stable needle when changing load.

2. Flash allowing 3 seconds before removing the DC volts.

3. Disconnect the AVR (wires 3 and 4) start the generator and remeasure the "residual" voltage, if this voltage is now greater than 5 Vac, reconnect the voltage regulator. But if less than 5 Vac repeat the field flashing procedure.

4. FIELD FLASHING

When the regulator is operated for the first time the polarity of residual magnetism may be reversed or too small to achieve the necessary

4. If repeating steps a and b does not result in generator voltage build-up, but residual is greater than 5 Vac, replace the voltage regulator.

5. TROUBLE SHOOTING

| SYMPTOM | CAUSE | CORRECTION |
|---------------------------|--|---|
| Voltage does not build up | Engine speed is too low. | refer to the Generator Manual. |
| | Residual voltage is too low. | refer to the section introduction of excite. |
| | B,C,F+,F- wires are not connected well. | refer to Figure 2 ~ Figure 5. |
| | Defective Generator. | refer to the Generator Manual. |
| Out voltage low | The input wiring of A,B,C are not correct. | refer to Figure 2 ~ Figure 5. |
| | Check the external potentiometer. | Check wiring and potentiometer. |
| | Under frequency. | refer to the Generator Manual. |
| | The exciter does not match the AVR. | refer to the Generator Manual. |
| Fuse blown | The voltage / frequency selector setting is not correct. | refer to Figure 7. |
| | The exciter flash is too large or wiring doesn't connect well. | refer to the Generator Manual. refer to Figure 2 ~ Figure 5. |
| Out voltage high | A,C terminals are not connect or wiring incorrect. | refer to Figure 2 ~ Figure 5. |
| | The voltage / frequency selector setting is not correct. | refer to Figure 7. |
| Out voltage instable | Stability Adjustment doesn't adjust well. | refer to the section introduction of Adjustment. |

6. FIGURE AND SIZE

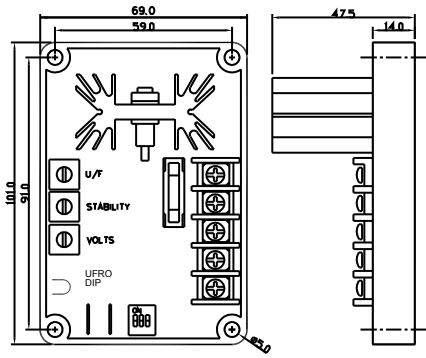

Fig. 1

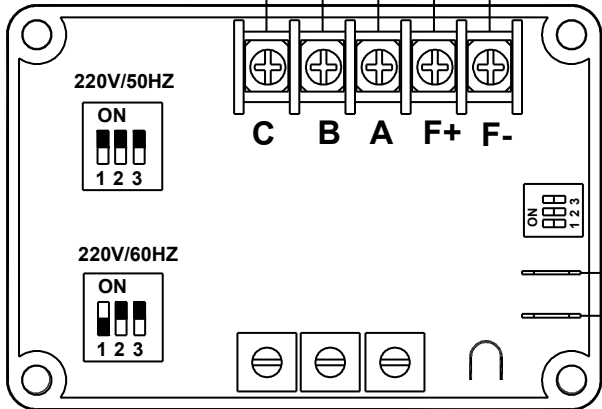
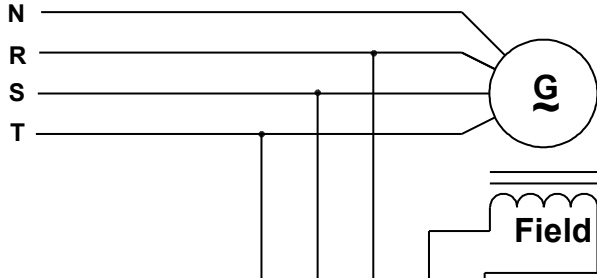
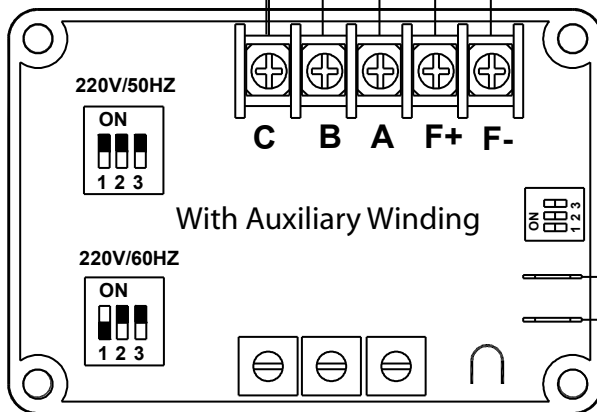
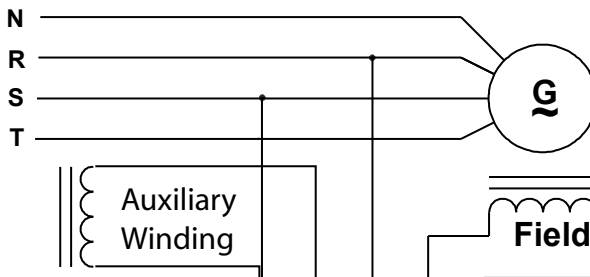

Fig. 2

U/F STAB VOLT UFRO DIP



With Auxiliary Winding

U/F STAB VOLT UFRO DIP

Fig. 10

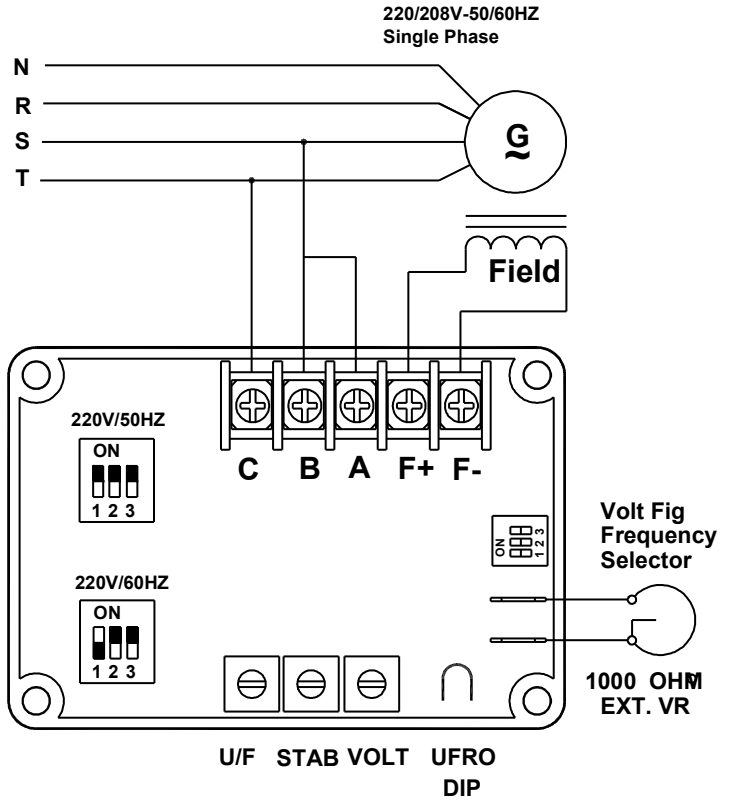

Fig. 3

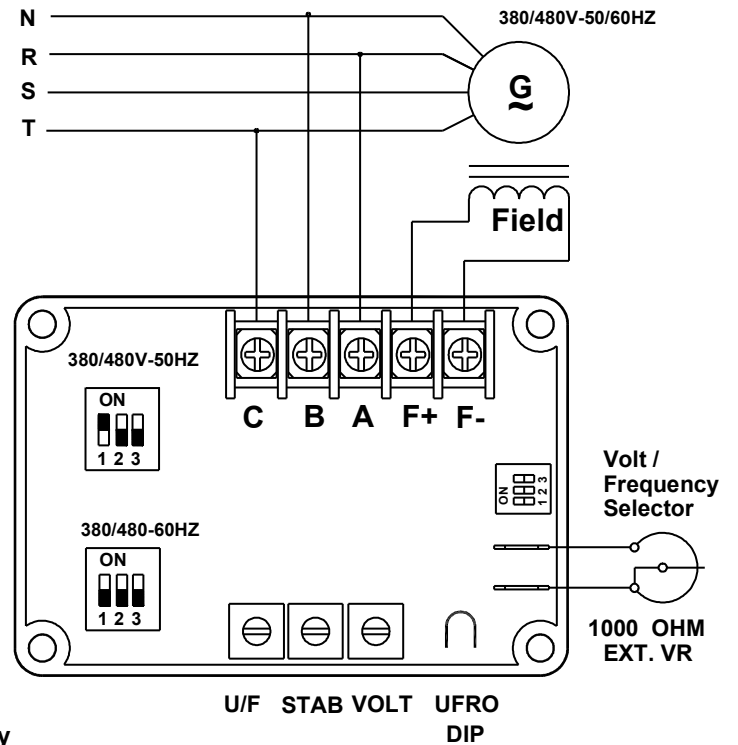

Fig. 4

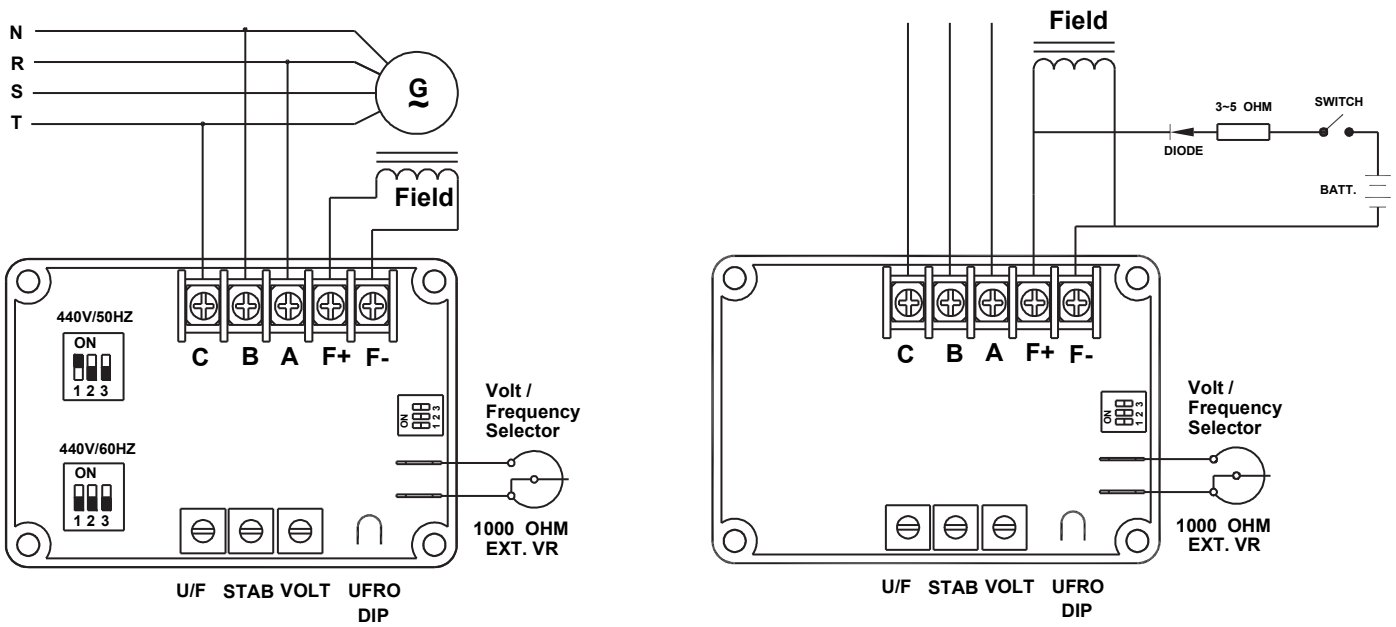

Figure 5

Flash with Battery
Figure 6

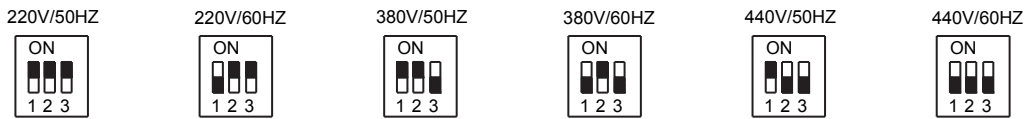
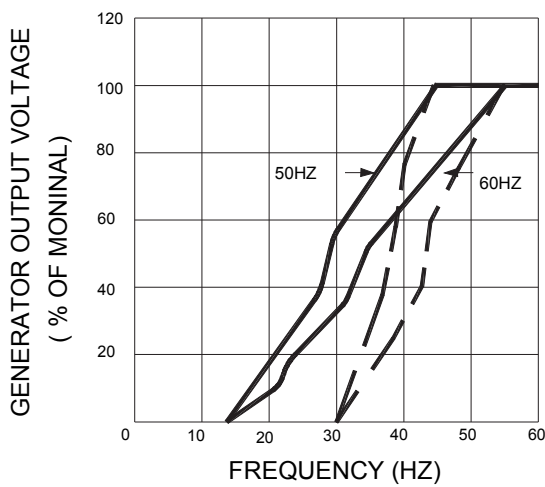
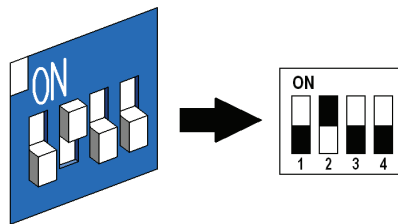
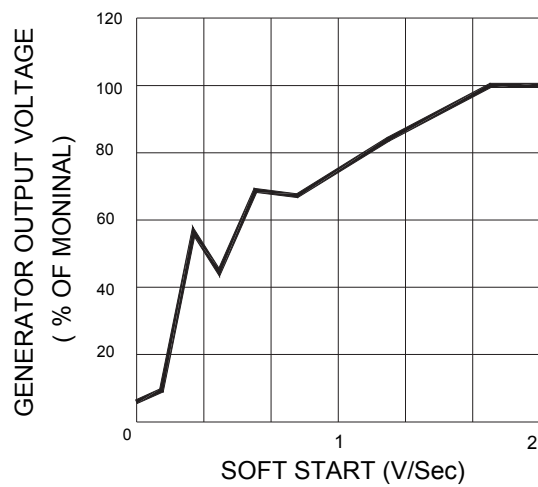

Figure 7



Frequency Compensation Curves

Figure 8



Soft Start Curve

Figure 9